

Index

Linear Booth, Corner Booth and Perimeter Booth	2
End-cap Booth and Peninsula Booth	3
Split Island Booth and Island Booth	4
Other Important Considerations	5
Issues Common To All Booth Types	6-7
Advisory Notes To Exhibition Organizers	8

The International Association for Exposition Management (IAEM) Guidelines for Display Rules and Regulations were originally created to promote continuity and consistency among North American exhibitions. Since their introduction, they have become the model for most domestic exhibitions.

This revised edition of IAEM's Guidelines is offered as a resource for exhibition organizers to use in creating consistent and fair exhibiting standards for their events. The text and illustrations have been clarified and updated with the intent of affording exhibitors a maximum return on their exhibit investments. Compliance with fire, safety, ADA and other government requirements has also been addressed.

It is IAEM's goal that the Display Rules and Regulations ultimately developed by each exhibition organizer shall provide exhibitors with all the information necessary to properly design and build exhibits, as well as plan their booth's layout and content. Organizers should also present the professional standards expected of exhibitors. Finally, they should assure all exhibitors, regardless of exhibit size or location, an environment conducive to successful interaction with their audiences.

© 2000 IAEM
No part may be reproduced without the express consent of IAEM

Linear Booth

Linear Booths have only one side exposed to an aisle and are generally arranged in a series along a straight line. They are also called “in-line” booths.

Dimensions

For purposes of consistency and ease of layout and/or reconfiguration, floor plan design in increments of ten feet (10') has become the de facto standard in the United States. Therefore, unless constricted by space or other limitations, Linear Booths are most commonly ten feet (10') wide and ten feet (10') deep, i.e. 10'x10'. A maximum backwall height limitation of eight feet (8') is generally specified.

Use of Space

Regardless of the number of Linear Booths utilized, (e.g. 10'x20', 10'x30, 10'x40', etc.) display materials should be arranged in such a manner so as not to obstruct sight lines of neighboring exhibitors. The maximum height of eight feet (8') is allowed only in the rear half of the booth space, with a four-foot (4') height restriction imposed on all materials in the remaining space forward to the aisle. (Note: When three or more Linear Booths are used in combination as a single exhibit space, the four foot (4') height limitation is applied only to that portion of exhibit space which is within ten feet (10') of an adjoining booth.)

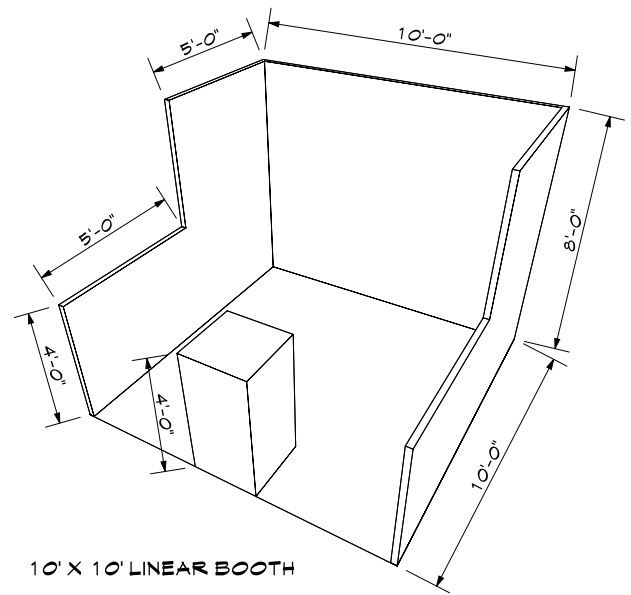

10' X 10' LINEAR BOOTH

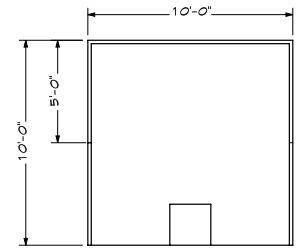

Plan

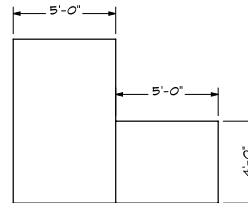

Left Side

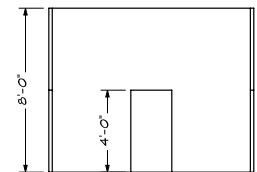

Front

Corner Booth

A Corner Booth is a Linear Booth exposed to aisles on two sides. All other guidelines for Linear Booths apply.

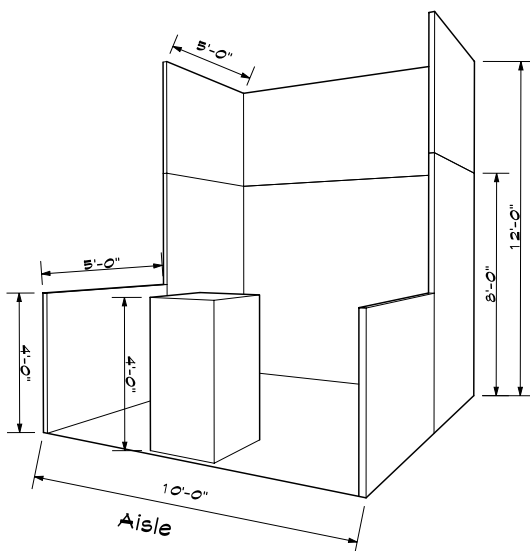

Perimeter Booth

A Perimeter Booth is simply a Linear Booth that backs to a wall of the exhibit facility rather than to another exhibit.

Dimensions and Use of Space

All guidelines for Linear Booths apply to Perimeter Booths except that the typical maximum backwall height is twelve feet (12').

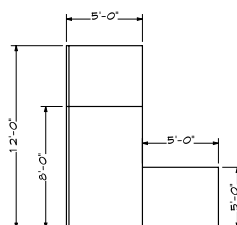

Left Side

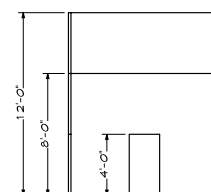

Front

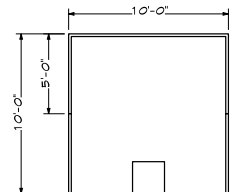

Plan

End-cap Booth

An End-cap Booth is exposed to aisles on three sides and composed of two booths.

Dimensions

End-cap Booths are generally ten feet (10') deep by twenty feet (20') wide. The maximum backwall height of eight feet (8') is allowed only in the rear half of the booth space and within five feet (5') of the two side aisles with a four foot (4') height restriction imposed on all materials in the remaining space forward to the aisle.

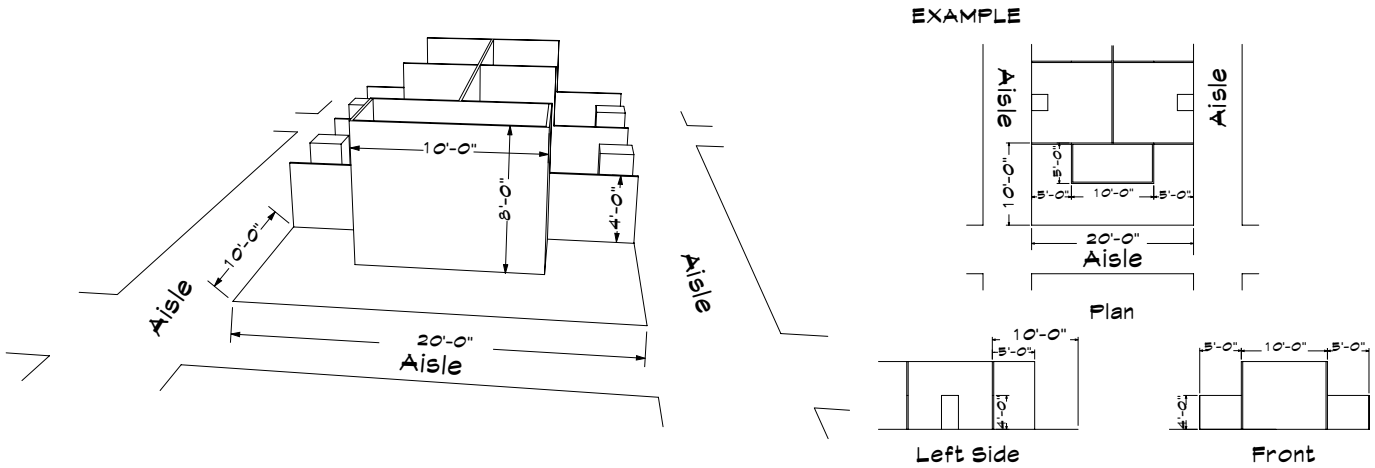

Peninsula Booth

A Peninsula Booth is exposed to aisles on three (3) sides and composed of a minimum of four booths. There are two types of Peninsula Booths: (a) one which backs up to Linear Booths, and (b) one which backs to another Peninsula Booth and is referred to as a "Split Island Booth."

Dimensions

A Peninsula Booth is usually 20' x 20' or larger. When a Peninsula Booth backs up to two Linear Booths, the backwall is restricted to four feet (4') high within five feet (5') of each aisle, permitting adequate line of sight for the adjoining Linear Booths. Sixteen feet (16') is a typical maximum height allowance, including signage for the center portion of the backwall.

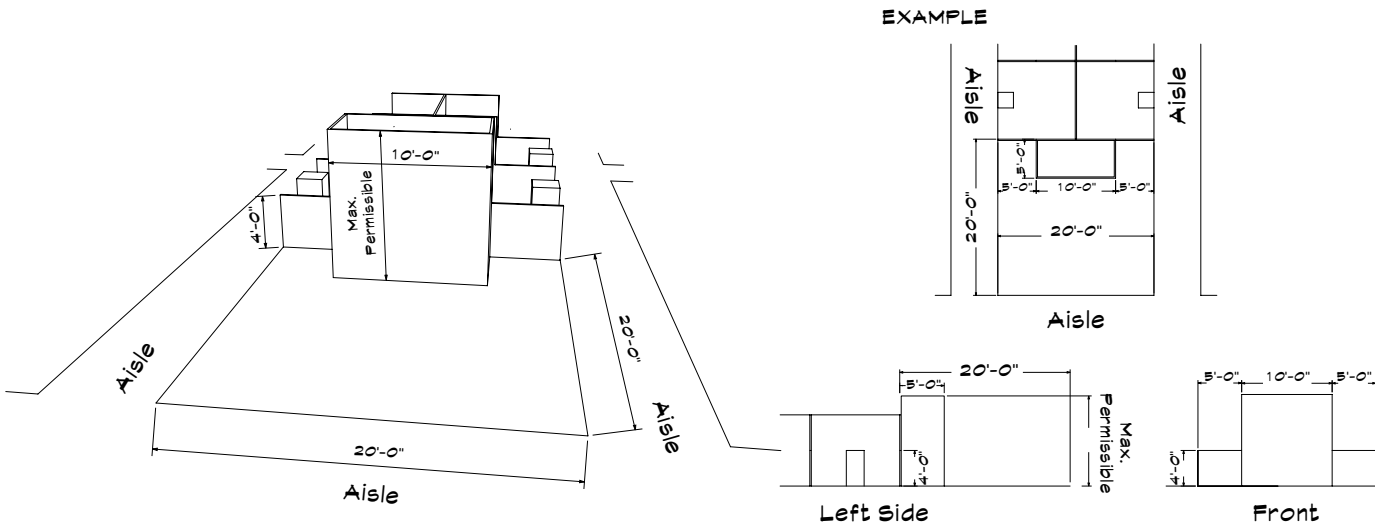

Split Island Booth

A Split Island Booth is a Peninsula Booth which shares a common backwall with another Peninsula Booth. The entire cubic content of this booth may be used, up to the maximum allowable height, without any back wall line of sight restrictions. Sixteen feet (16') is a typical maximum height allowance, including signage. The entire cubic content of the space may be used up to the maximum allowable height.

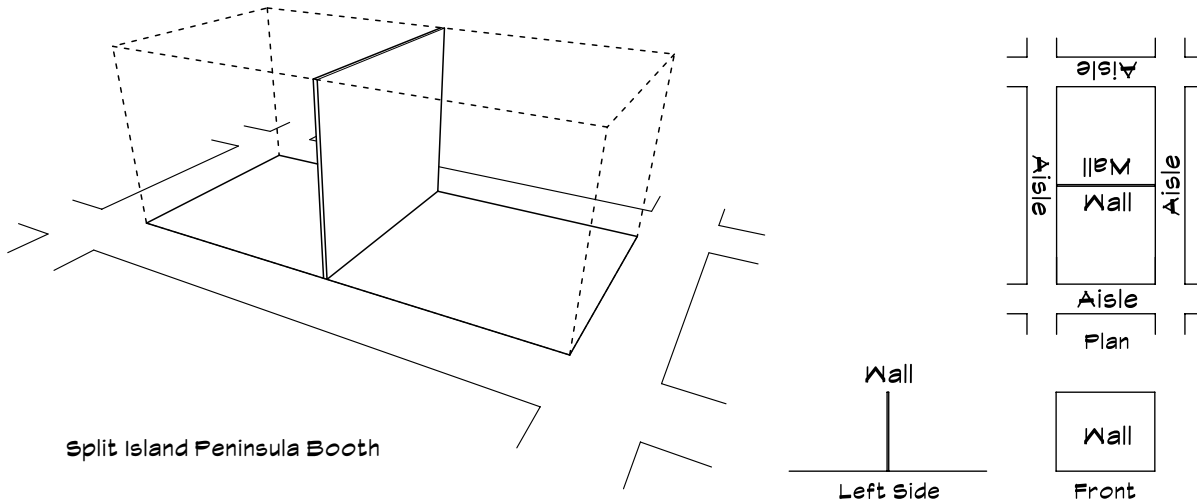

Island Booth

An Island Booth is any size booth exposed to aisles on all four sides.

Dimensions

An Island Booth is typically 20' x 20' or larger, although it may be configured differently.

Use of Space

The entire cubic content of the space may be used up to the maximum allowable height, which is usually sixteen feet (16'), including signage.

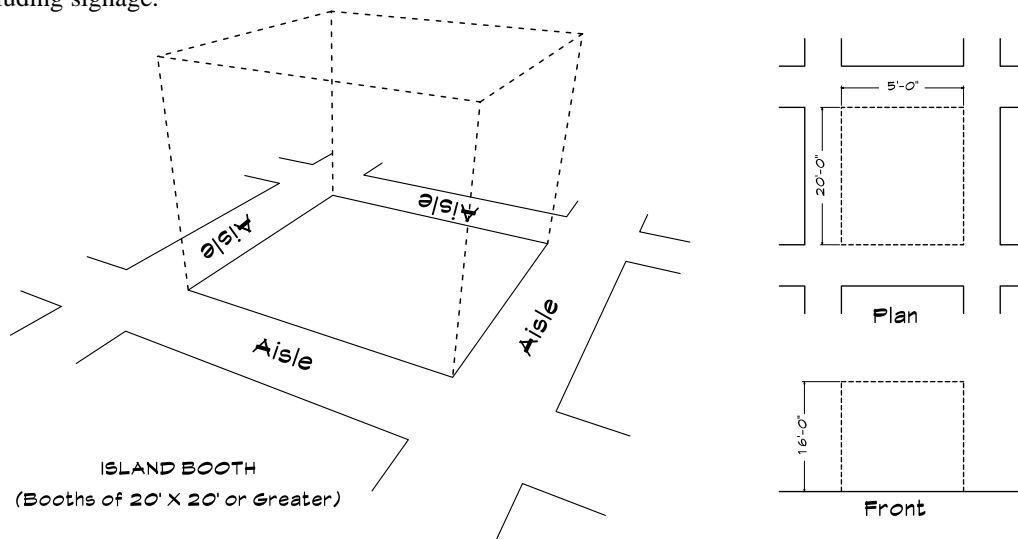

Other Important Considerations

Canopies and Ceilings

Canopies, including ceilings, umbrellas and canopy frames, can be either decorative or functional (such as to shade computer monitors from ambient light or for hanging products). Canopies for Linear or Perimeter Booths should comply with line of sight requirements (see “Use of Space for Linear or Perimeter Booths”).

The base of the Canopy should not be lower than seven feet (7') from the floor within five feet (5') of any aisle. Canopy supports should be no wider than three inches (3"). This applies to any booth configuration that has a sightline restriction, such as a Linear Booth. Fire and safety regulations in many facilities strictly govern the use of canopies, ceilings and other similar coverings. Check with the appropriate local agencies prior to determining specific exhibition rules.

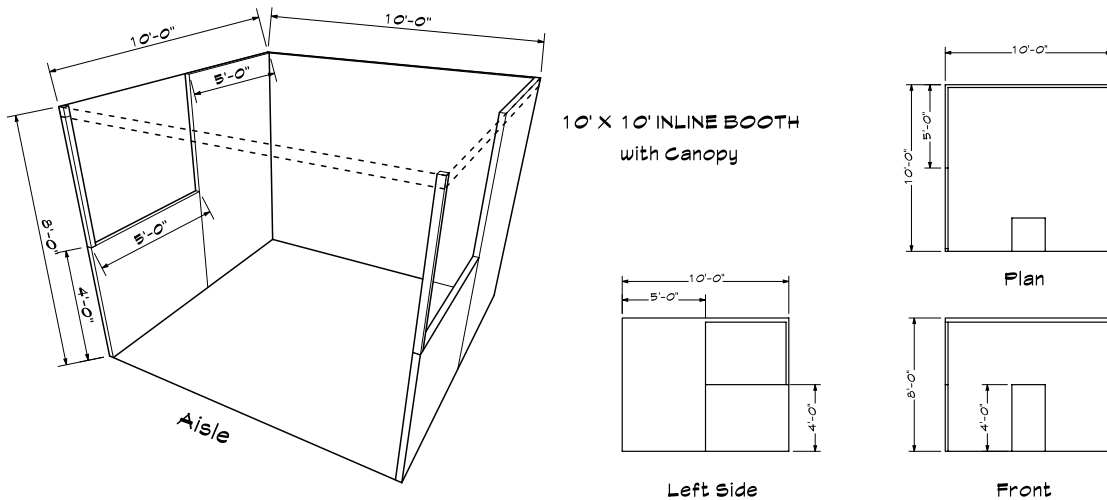

Hanging Signs & Graphics

Hanging signs and graphics are permitted in all standard Peninsula and Island Booths, usually to a maximum height of sixteen feet (16'). Whether suspended from above or supported from below, they should comply with all ordinary use-of-space requirements (for example, the highest point of any sign should not exceed the maximum allowable height for the booth type).

Hanging Signs & Graphics should be set back ten feet (10') from adjacent booths.

Approval for the use of Hanging Signs & Graphics should be received from the exhibition organizer at least 60 days prior to installation. Drawings should be available for inspection.

Towers

A Tower is a freestanding exhibit component separate from the main exhibit fixture. The height restriction is the same as that which applies to the appropriate exhibit configuration being used.

Towers in excess of eight feet (8') should have drawings available for inspection. Fire and safety regulations in many facilities strictly govern the use of towers. A building permit may be required.

Multi-story Exhibit

A Multi-story Exhibit is a booth where the display fixtures exceed twelve feet (12'), including Double-decker and Triple-decker Booths. In many cities, a Multi-storied Exhibit requires prior approval by the exhibit facility and/or relevant local government agency because it is deemed to be a “structure” for building purposes. The city building department generally needs to issue a building permit based on an application and drawings prepared and submitted by a licensed architect or engineer. Exhibitors should obtain local building regulations early on to ensure that all time constraints are met. Exhibition organizers should be prepared to assist exhibitors in this application process.

Issues Common To All Booth Types

Americans with Disabilities Act (ADA)

All exhibiting companies are required to be in compliance with the Americans with Disabilities Act (ADA) and are encouraged to be sensitive, and as reasonably accommodating as possible, to attendees with disabilities. Information regarding ADA compliance is available from the U.S. Department of Justice ADA Information Line (800-514-0301) and from web site www.usdoj.gov/crt/ada/infoline.htm.

Structural Integrity

All exhibit displays should be designed and erected in a manner that will withstand normal contact or vibration caused by neighboring exhibitors, hall laborers or installation/dismantling equipment such as fork lifts. Displays should also be able to withstand moderate wind effects that may occur in the exhibit hall when freight doors are open. Refer to local building codes that regulate temporary structures.

Exhibitors should ensure that any display fixtures such as tables, racks or shelves are designed and installed properly to support the product or marketing materials to be displayed upon them.

Flammable and Toxic Materials

All materials used in display construction or decorating should be made of fire retardant materials and be certified as flame retardant. Samples should also be available for testing. Materials that cannot be treated to meet the requirements should not be used. A flameproofing certificate should be available for inspection.

Exhibitors should dispose of any waste products they generate during the exhibition in accordance with guidelines established by the Environmental Protection Agency and the facility.

Electrical

Every exhibit facility has different electrical requirements; however, minimum guidelines are suggested:

- All 110-volt wiring should be grounded three-wire.
- Wiring that touches the floor should be “SO” cord (minimum 14-gauge/three-wire) flat cord, which is insulated to qualify for “extra hard usage”.
- Cord wiring above floor level can be “SJ” which is rated for “hard usage”.
- Using zip cords, two-wire cords, latex cords, plastic cord, lamp cord, open clip sockets, and two-wire clamp-on fixtures is not recommended and is often prohibited. Cube taps are not recommended and are often prohibited.
- Power strips (multi-plug connectors) should be UL approved, with built-in over-load protectors.

Lighting

Exhibitors should adhere to the following suggested minimum guidelines when determining booth lighting:

- No lighting, fixtures, lighting trusses or overhead lighting are allowed outside the boundaries of the exhibit space. Exhibitors intending to use hanging light systems should submit drawings to exhibition management for approval.
- Lighting should be directed to the inner confines of the booth space. Lighting should not project onto other exhibits or show aisles.
- Lighting which is potentially harmful, such as lasers or ultraviolet lighting, should comply with facility rules and be approved in writing by exhibition management.
- Lighting that spins, rotates, pulsates and other specialized lighting effects should be in good taste and not interfere with neighboring exhibitors or otherwise detract from the general atmosphere of the event.

Storage

Fire regulations in most exhibit facilities prohibit storing product, literature, empty packing containers or packing materials behind back drapes or under draped tables. In most cases, however, exhibitors may store a limited supply of literature or product appropriately within the booth area, so long as these items do not impede access to utility services, create a safety problem or look unsightly.

Demonstrations

As a matter of safety and courtesy to others, exhibitors should conduct sales presentations and product demonstrations in a manner which assures all exhibitor personnel and attendees are within the contracted exhibit space and not encroaching on the aisle or neighboring exhibits. It is the responsibility of each exhibitor to arrange displays, product presentation and demonstration areas to ensure compliance.

Special caution should be taken when demonstrating machinery or equipment that has moving parts, cooking equipment with an open flame, or any product that is otherwise potentially dangerous. Exhibitors should establish a minimum setback of three feet (3') and/or install hazard barriers as necessary to prevent accidental injury to spectators. Sound demonstrations should not exceed 85 decibels. Additionally, demonstrations should only be conducted by qualified personnel.

Sound/Music

In general, exhibitors may use sound equipment in their booths so long as the noise level does not disrupt the activities of neighboring exhibitors. Speakers and other sound devices should be positioned so as to direct sound into the booth rather than into the aisle. Rule of thumb: Sound and noise should not exceed 85 decibels.

Exhibitors should be aware that music played in their booths, whether live or recorded, may be subject to laws governing the use of copyrighted compositions. ASCAP, BMI and SESAC are three authorized licensing organizations that collect copyright fees on behalf of composers and publishers of music.

Advisory Notes To Exhibition Organizers

End-cap Booths: End-cap Booths cause more problems between exhibitors than any other type of booth, because most exhibitors fail to observe backwall height restrictions. Exhibition managers should be alert to exhibitors' reserving End-Cap configurations to ensure they do not violate Linear Booth line-of-sight regulations for neighboring exhibits.

Fire Equipment: Fire hoses and extinguishers should be visible and accessible at all times.

Hanging Signs: Although the Guidelines indicate sixteen feet (16') maximum height, some exhibitions permit eighteen feet (18'), twenty feet (20') or no limit. Caution should be exercised so exhibitors will not compete over air space for hanging signs.

Exhibitors should be advised to install "hanging points" at the time of manufacture of the sign or display.

Hardwall Booths: Expositions that provide Hardwall Booths should specify if these structures can be used for display and attaching products.

Line of Sight: It is common at certain events, such as gift and craft shows, to eliminate the line-of-sight requirement for Linear, End-Cap and Peninsula Booths that back up to Linear Booths. This permits exhibitors to utilize the full cubic content of the booth.

Perimeter Openings: Large peninsulas and islands with long high walls can create a "tunnel-like" effect. Exhibitors may be required to install a minimum six-foot (6') opening every thirty feet (30').

Pipe and Drape: These are commonly used at exhibitions to define exhibits. Exhibition managers often include in their Rules and Regulations that this equipment is not intended as a display fixture. Therefore product and signs should not be attached or affixed.

Product Height: Some exhibitors have products that exceed display height restrictions. Exhibition organizers should establish guidelines for displaying such products. For example, some shows require that these exhibitors reserve only perimeter space. Products exceeding height restrictions for Islands and Peninsulas are usually permitted.

Vehicles: Rules vary depending on the facility, but generally it is required that vehicles on display have no more than a 1/4 tank of gas. The filler cap should be sealed and the batteries disconnected. External chargers are usually recommended for demonstration purposes.



International Association for Exposition Management

P.O. Box 802425 • Dallas, Texas 75380

+1 972.458.8002 *phone* • +1 972.458.8119 *fax* • www.iaem.org • iaem@iaem.org